

TECHNICAL BULLETIN

NO. 692A

GENERAL GUIDELINES FOR MARINE DESIGNERS

GENERAL GUIDELINES

The CHOCKFAST system is used for mounting all sizes and types of main and auxiliary machinery. It eliminates all machining of foundation surfaces and will conform precisely to the surface profiles presented. The individual chocks are arranged similarly to conventional iron ones. Removal of grease, oil, mill scale and/or rust or flaky paint is the only preparation usually necessary for machinery supporting surfaces. These surfaces should be cleaned if covered by other than a thin coat of inorganic zinc paint or similar primer. Inorganic zinc is recommended where machinery base and foundation corrosion resistance is required, as in the case of deck machinery and other equipment constantly exposed to water.

Which Grade of CHOCKFAST to Use

When alignment must be maintained precisely, or when the operating temperature will exceed 52C (125F) but not 90C (194F), then CHOCKFAST ORANGE must be used. Examples of this class of machinery are propulsion engines and gearboxes.

Where alignment does not have to be maintained precisely, usually because the equipment is self-contained, and the operating temperature will be below 52°C (125°F), then CHOCKFAST ORANGE or CHOCKFAST GRAY may be used. Typical applications would be winches, pumps and skid mounted diesel generators.

Design for Precise Alignment (Propulsion machinery, etc.)

- Stress on the chocks due to the machinery's weight should not exceed 7 kgf/cm² (100 psi). Known as deadweight loading.
- Static stress on the chocks due to the Deadweight plus the Bolt Tensions is typically designed to be 35 kgf/cm² (500 psi). See the appropriate classification approval for higher stress, most approve at least 45 kgf/cm² (640 psi)
- Hold down bolt tensions must total at least 2.5 times the machinery weight. This is to ensure the machine will not move.

d. Hold down bolt stress must be at least 4.73 kgf/mm² (6720 psi). This is to ensure the bolts will stay tight.

e. Continuous chock temperature should not exceed 90C (194F). Unless otherwise stated it may be assumed that a diesel engine's chocks will not exceed 80C (176F).

f. Where thrust has to be transmitted, thrust chocks are not required if the total static chock load exceeds 3.33 times the thrust.

It is suggested that chocks be designed for 12mm to 45mm (1/2" to 1' 3/4") thickness. Any thickness of chock can be cast. Consult your distributor for advice on thinner or thicker chocks.

Design for Deck and Auxiliary Machinery

If the temperature will not exceed 52C (125F), machinery and equipment which does not have to be precisely aligned may be chocked as follows:

Using CHOCKFAST ORANGE, maximum continuous static stress 84.5 kgf/cm² (1200 psi). Using CHOCKFAST GRAY, maximum continuous static stress 56 kgf/cm² (800 psi). It is not necessary to limit the deadweight loading. Chock thickness recommendations are as for precise alignment.

Design for Higher Stress than 84.5 kgf/cm² (1200 psi), Non-Critical Alignment

When the chock stress will be above the previously given limits it is advisable to consult *ITW Philadelphia Resins*. Continuous stress of 250 kgf/cm² (3550 psi) has been approved for mooring winches and this is also a typical stress under crane rails. Transients and shock loads of 700 kgf/cm² (10000 psi) can be accepted with suitable design guidance.

↓ NEXT PAGE ↓

General Guidelines for Marine Engineers

Bolt Tension and Tightening Torque

There is no absolute relationship between tightening torque and bolt tension. The generally accepted formula is:

$$\begin{aligned} \text{Torque (kgf.m)} &= \frac{0.2 \times \text{Tension (kgf)} \times \text{Dia. (mm)}}{1,000} \\ \text{Torque (lbs.feet)} &= \frac{0.2 \times \text{Tension (lbs)} \times \text{Dia. (inches)}}{12} \\ \text{Torque (N.m)} &= \frac{0.2 \times \text{Tension (N)} \times \text{Dia. (mm)}}{1,000} \end{aligned}$$

As has been explained, there is a minimum desirable bolt stress and the following table gives the **MINIMUM** tension for various size bolts. ***It is normally advantageous to use more than the minimum shown here.*** When the bolt material is unknown, a safe maximum tension is 3 times the value given in this table.

DIAMETER (mm)	MINIMUM TORQUE (kg.m)	MINIMUM TENSION (kg)	DIAMETER (in)	MINIMUM TORQUE (lbs.ft)	MINIMUM TENSION (lb)
12	3	570	1/2"	20	1320
14	4	770	5/8"	30	2062
16	5	1000	3/4"	45	2970
18	7	1275	7/8"	75	4042
20	10	1570	1"	90	5279
22	12	1900	1 1/8"	126	6681
24	14	2265	1 1/4"	172	8248
27	16	2965	1 3/8"	230	9980
30	22	3670	1 1/2"	300	11877
33	30	4545	1 5/8"	380	13939
36	40	5555	1 3/4"	475	16166
39	50	6410	1 7/8"	580	18558
42	60	7145	2"	705	21115
45	75	8335	2 1/8"	845	23836
48	90	9375	2 1/4"	1005	26723
52	110	10580	2 3/8"	1180	29775
56	140	12500	2 1/2"	1375	32991
60	170	14165	2 5/8"	1600	36373
64	200	15625	2 3/4"	1830	39920
68	250	18382	2 7/8"	2090	43631

CONVERSION FACTORS lbs.ft to kgf.m multiply by 0.138
 kgf.m to lbs.ft multiply by 7.23 kg to lbs multiply by 2.2
 N.m to kgf.m multiply by 0.102 lbs to kg multiply by 0.45

CALCULATION EXAMPLE - PROPULSION ENGINE

Engine weight	75,000kg	150,000lbs(A)
Bolts 18 pieces	M42	1 3/4"
Engine weight x 2.5	187,500kg	375,000lbs
Each bolt tension / 18	10417kgf	20834lbs
Minimum permitted tension	7145 kgf	16166lbs
Therefore bolt requirements are satisfied		
Minimum chock area	$75,000 / 7 = 10715 \text{ cm}^2$	$150,000 / 100 = 1500 \text{ in}^2$
Assume 18 chocks, each chock	596cm ²	83.4in ²
Bolt hole area	16cm ²	2.76in ²
Assume chock projects under engine	19.5cm	7 3/4"
Chock length	$(596 + 16) / 19.5 = 31.5 \text{ cm}$	$(83.4 + 2.76) / 7.75 = 11 1/8"$
Each chock is	315 x 195 mm	11 1/8" x 7 3/4"

QUANTITY TO ORDER

The quantity of CHOCKFAST required is the volume of the chocks plus their overpours. The second section of this bulletin, "[Application Instructions - Marine](#)", explains the overpours. It is advisable to order an extra 10% to allow for chock thickness variations and wastage. Damming foam, mixing blades, sealing putty, release agent and non melt grease are also available from ITW Philadelphia Resins. CHOCKFAST is packaged in premeasured units of resin and hardener as follows:

CHOCKFAST ORANGE:

3.4kgs (7.5lbs) and 6.8kgs (15lbs)
 1966cc (120in³) and 4261cc (260in³)

CHOCKFAST GRAY:

5kgs (11lbs) and 21.8kgs (48lbs)
 3064cc (187in³) and 13372cc (816in³)

↓ NEXT PAGE ↓

[Application Instructions - Marine](#)

**GENERAL INSTRUCTIONS FOR USING ITW PHILADELPHIA RESINS
 POURABLE CHOCKING COMPOUNDS**

These instructions apply to normal CHOCKFAST installations on steel foundations, where the chock thickness are within the ranges:

CHOCKFAST ORANGE 12mm-70mm (1/2" - 2 3/4")

CHOCKFAST GRAY 12mm-50mm (1/2" - 2")

Outside these ranges please consult your CHOCKFAST distributor for guidance.

I. MATERIALS REQUIRED

1. CHOCKFAST ORANGE. Calculate from the chock Plan the amount required based on 1966 cc (120 cu.in.) per 3.4 kg (7 lb.) unit, 4260 cc (260 cu.in.) per 6.8 kg (15 lb.) unit. Have an extra 10% available for chock thickness variation, accidental loss, etc. CHOCKFAST GRAY Calculate from the chock plan the amount required based on 3065 cc (187 cu.in.), or 13374 cc (816 cu.in.) for the two unit sizes. Have an extra 10% available for chock thickness variation, accidental loss, etc.
2. Damming materials:
 - a. flexible damming
 - b. metal front dams
 - c. sealing compound
 - d. contact adhesive where necessary
3. PR-225 Aerosol release agent.
4. No melt Grease.
5. Heavy duty hand electric drill with an operating speed of 200 rpm.
6. ITW Philadelphia Resins mixing blade, and spare.
7. Surface thermometer. An immersion thermometer is also useful.
8. Eye shields or goggles.
9. Slitting knife.
10. Protective gloves.
11. PRT-59 or other suitable solvent for cleaning mixer blade and spillage.
12. If the steel temperature is below 13C (55F), have sufficient heaters available to raise it above 15C (60F).

II. PREPARATIONS

1. Check that all materials are available.
2. Try to store the resin and hardener at 20C-25C (68F-77F) for at least the last 12 hours before use. This ensures the most suitable mixing and pouring viscosity.

3. The machine's alignment should be correct and all bolt holes should have been drilled. If they have not, core the hole through the chock space and bedplate with a wooden plug or Armaflex tubing,
4. Clean all surfaces that the CHOCKFAST will contact. They should be free from oil grease, water, rust or paint in poor condition. A good coat of primer is acceptable.

III. DAMMING

1. The picture sequence shows the general damming Procedure. Follow the dimensions given on the chock plan for the particular machine.

Fig. 1 : Trim Foam to Proper Height

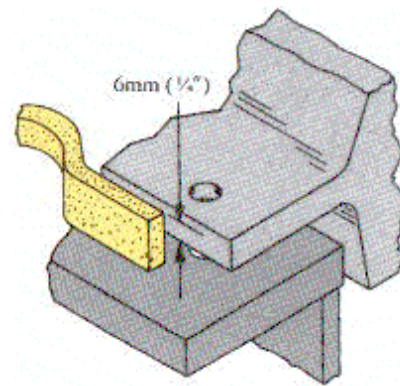

2. The bolt holes, except for fitted bolts, should preferably be plugged with Armaflex or wooden dowels. Alternatively the bolts may be in place with the nuts finger tight. Whatever is used to core the hole must be well coated with non-melt grease.

Fig. 2 : Insert Damming per Chocking Plan

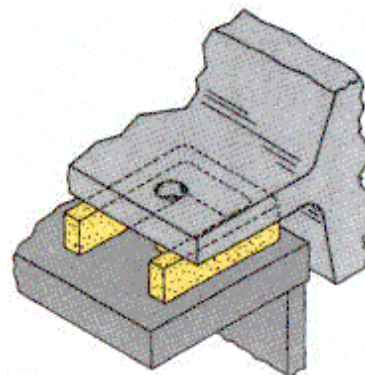

- Fitted bolts should be sprayed with PS-225 Release Agent and installed.

Fig. 3 : Plug Bolt Holes (with well greased plugs) Spray Chock Zone (with thin film of release agent)

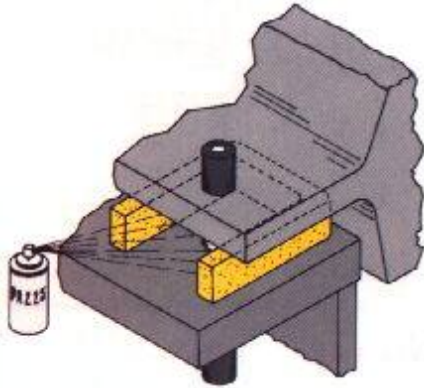

- Attach the front dam so that the overpour width and height will be within the limits shown. This is important.

Fig. 4 : Tackweld Front Dam. Insert Overpour Damming Components.

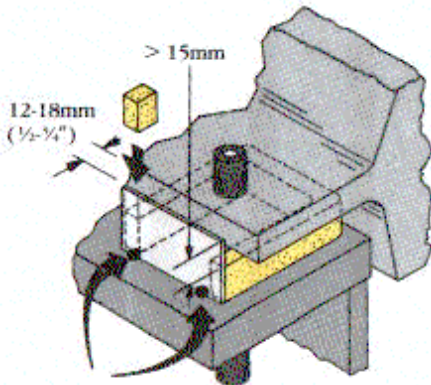

- Make sure all potential leaks are well sealed. It is easier to prevent leaks before the resin is poured than to stop them afterwards.

Fig. 5 : Seal Front Dam at Bottom. Spray its Inside Face with Release Agent.

- Measure chock thickness and the temperature of the engine bed and foundation.

Fig. 6 : Checkpoints - Chock height, foundation temperature

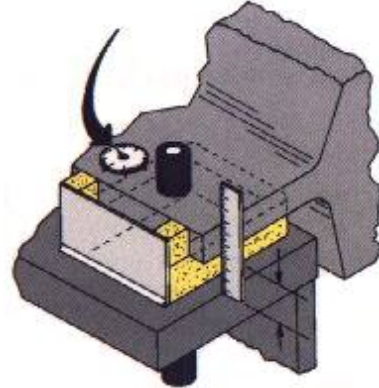

IV. MIXING AND POURING

- Ensure that all damming is complete.
- For CHOCKFAST ORANGE only, decide from the graph the amount of hardener to be used.
- Bring the resin and hardener from storage.
- Put on gloves and eye protection.
- Add the hardener to the resin can. power mix at about 200rpm, certainly not over 500rpm, for 3 minutes using the mixing blade recommended by your distributor. Keep the blade submerged and traversing the can. Make sure the bottom of the can is scoured
- Pour the resin as soon as possible after mixing. Do not scrape out the residue from the can sides and bottom..

Fig. 7 : Mix Resin and Hardener for 2-3 minutes.



Fig. 8 : Pour Into Lower End

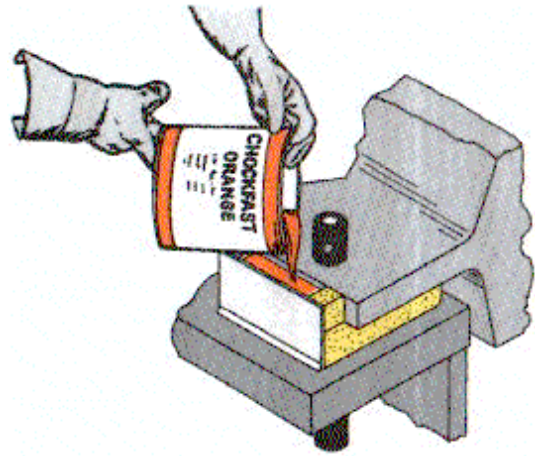
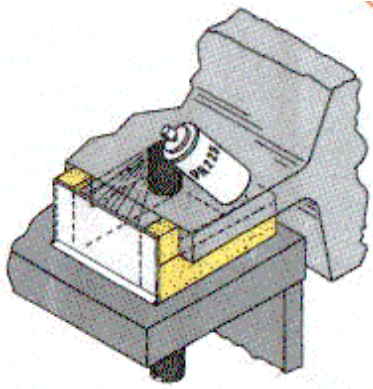

↓ NEXT PAGE ↓

V. AFTER POURING

1. Leaks can start at any time while the resin is still liquid. So, do not leave the machine until all the chocks have gone hard.
2. Make sure the temperature is at least 13C (55F), use heaters if necessary, and leave the chocks to cure. Allow at least the following time:
13C - 18C (55F - 65F) 48 hours
19C - 21C (66F - 70F) 24 hours
Above 21C (70F) 18 hours
3. When satisfied sufficient cure has taken place, remove the heaters, if used. Allow the chocks to come to ambient temperature.
4. Remove the front dams. Take the sharp edge off the overpour.
5. Release the jack screws, wedges or other alignment supports.
6. Tighten the hold down bolts to the desired tension or torque.

6. Fit the measuring pins if alignment is critical.

NOTE: CHOCKFAST ORANGE ONLY

Under some circumstances a reduced amount of hardener is used. Refer to Bulletin 693, excerpted below, or consult a Chockfast distributor for guidance. Because there are so many variables in chock size, chock thickness, metal temperature, heat sink, etc., it is advantageous to condition the resin to 20C - 25C (68F - 77F). The decision on exactly how much hardener to use is to be made by the technician in charge. Bulletin 693 and the graph below are a guide only.

For chocks less than 20mm (3/4") thick always use full hardener. For chocks less than 12mm (1/2") or chocks that must be poured in layers consult a Chockfast Distributor for advice. Always use maximum hardener with Chockfast Gray.

TECHNICAL SERVICE AND SUPERVISION ARE READILY AVAILABLE. CONTACT YOUR [LOCAL DISTRIBUTOR](#).

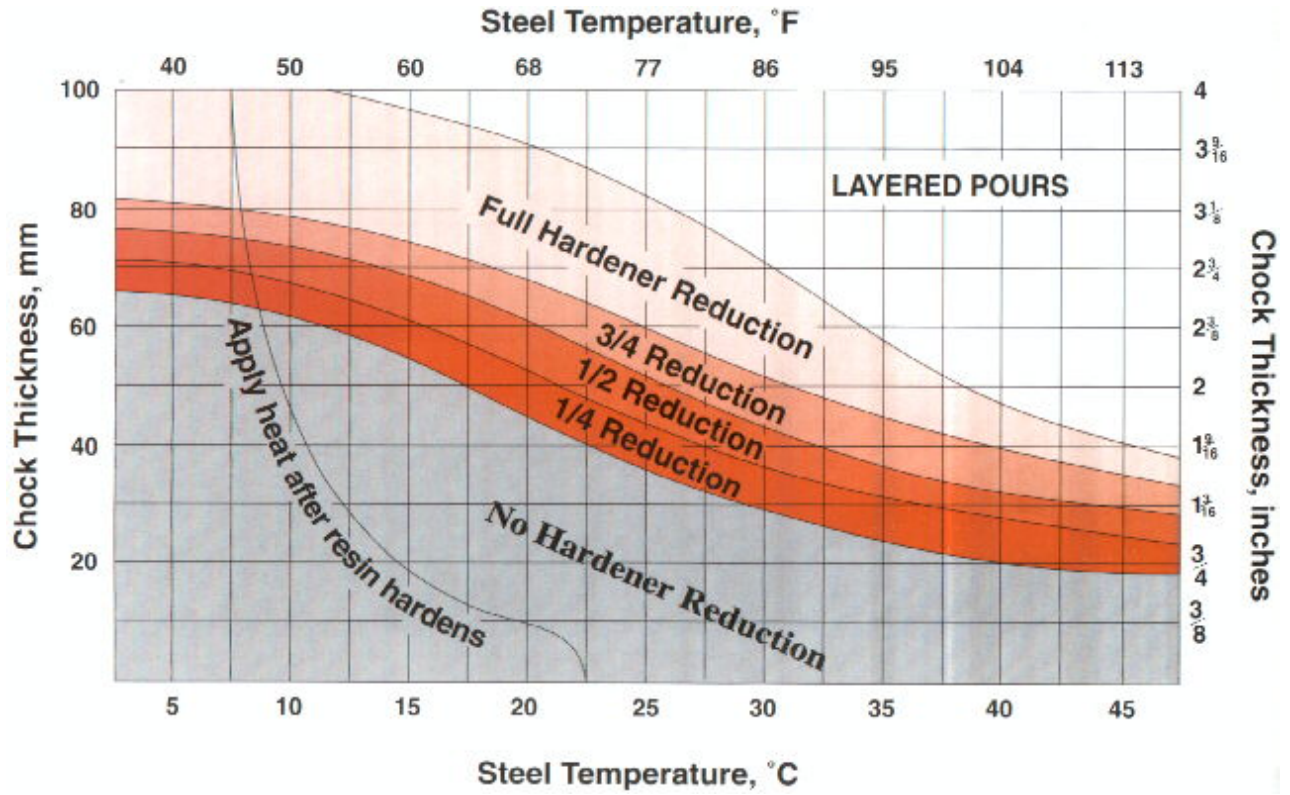

[Chockfast Home](#)

[Technical Bulletins](#)

[Contact us](#)

[Approvals](#)

[MIC SA Home](#)

[Legal Notice](#)

Copyright 2000 by [marine industrial concerns s.a.](#)

All rights reserved. E-mail comments to [Webmaster](#)

Updated 16.12.2004